



KTM SERIES EB7 UNIBODY FLOATING BALL VALVES

INSTALLATION AND OPERATION MANUAL



1 STORAGE

The valves ball, seats and end connections should be adequately protected against damage. The protective end covers should not be removed until ready for installation.

For long term storage of ball valves the manufacturer would recommend the following procedures be adopted:

- Protection for carbon steel valves, internals of valve should be sprayed with WD-40 or similar. To achieve this, turn the valve to the half open position and direct the atomized spray mist into the open valve cavity. Repeat from the other side of the valve.
- Operation carbon steel and stainless steel valves should be cycled every three months. The cycle operation should be to the full close then to the full open position.
- Storage all valves should be stored in the fully open position or fully closed position. End protection caps or covers should remain on the valve at all times.

CAUTION

The ball valves are delivered with the ball in the full-open position and should be stored as they are. Keeping the ball in other positions or half-open position for an extended period of time could cause seat leakage.

NOTE

- For valves stored in the fully closed position due to spring failure mode of the actuator, the surface of the ball should be free of dust or any other contaminants before cyclic operation.
- Do not place consignment package directly on the ground.
- Do not expose consignment packages to the rain/wind or directly to the sun.
- Storage in an open area for a limited period can be considered only if the valves have appropriate packing (packed in cases covered with vinyl sheets protecting from rain, wind, dust etc, and contents well protected with barrier sacks.)
- Store in a dry and well ventilated condition.
- If storage is anticipated for an extended period, the desiccant bags (if supplied) should be changed every 6 months.

1.1 Pipe compatibility

KTM ball valves are suitable for installation into most piping systems. The standard end connections are:

- Flanged ANSI Class 150 and Class 300

1.2 Selection

Ensure the valve's materials of construction and pressure/temperature limits shown on the nameplate are suitable for the process fluid and conditions. If in doubt contact the manufacturer.

1.3 Unpacking

On receipt, all valves should be inspected for loose or damaged parts, and if necessary claims promptly submitted. Valves are shipped on pallets or sealed wooden frame cases. Protective end coverings should remain on valves until ready for installation. Valves with spring return actuators are shipped in the 'open' or 'closed' position depending on failure mode of actuator. They should be stored under cover. Caution should be exercised to ensure that they are not subjected to moisture, dirt, sand or foreign matter. Valves should never be left for any period of time in an intermediate position between 'open' and 'closed'.

KTM SERIES EB7 UNIBODY FLOATING BALL VALVES

INSTALLATION AND OPERATION MANUAL

2 SAFETY PRECAUTIONS

Whenever a valve is being installed or removed from the pipeline, ensure the line is not pressurized and any hazardous medium is drained away.

Slowly cycle the valve several times to relieve the cavity area and leave in the open position. Check that the seat and body pressure ratings are suitable for the service prior to installation. These ratings must not be exceeded.

General

The Unibody valves are all bi-directional valves, controlling flow in either direction. They can be installed in any position, horizontally or vertically. Gaskets are required to fit between valve flanges and pipeline. Check gaskets are suitable for duty.

WARNING

For safety reasons, it is important to take the following precautions before working on the valve:

- 1. Personnel making any adjustments to the valve should utilize equipment and clothing normally used to work with the process where the valve is to be installed.*
- 2. The line must be depressurized, drained and vented before installing the valves.*
- 3. Handling and installation of all valves, operators and actuators must be carried out by personnel trained in all aspects of installation and manual/mechanical handling techniques.*
- 4. Ensure the valve pressure/temperature limitations marked on the nameplate are above or equal to the service conditions.*
- 5. Double seated valves on liquid service, which may be subjected to rapidly increasing temperatures in the closed position, will need a positive means of relieving for excessive cavity pressures. For further information, contact the manufacturer.*

2.1 Line installation

Caution should be exercised to prevent damage of the valve sealing mechanism during installation. The following steps will assist in complying with the correct installation procedure.

Remove the protective end covers prior to installation. This should be done preferably in a dust free environment. The gasket faces should be wiped with clean solvent to ensure gasket faces are clean.

Substantial supports should be provided for the free ends of the pipeline and for the valve during installation. Unsupported pipelines hung from valves can originate high stress in valve body causing leaks or possible damage.

Where possible, leave valve in 'open' position until entire construction work has been completed, pipeline cleaned and plant is ready for start up. Valves should never be left for any period of time on an intermediate position between 'open' and 'closed', as this could cause permanent damage to the resilient seating material.

2.2 Orientation

Valves are fully bi-directional and can be fitted either way. For optimum flow performance, one piece Unibody flanged valves should be fitted with the removable insert end upstream, if the flow is predominately in one direction only. Full bore valves have no preferred orientation relative to flow.

2.3 Long term storage

Valves which have been stored in the open position may take time to reseat when first installed. To assist in obtaining tight shut-off after storage the procedure steps outlined below should be followed:

1. Remove protective end cover from valve.
2. Wipe internal bore with clean rag to remove dust etc.
3. Cycle valve to the closed position and leave for 24 hours sitting in close position.
4. Prior to installation open valve.

2.4 Flanged valves

Fit gaskets of suitable material, place in position on the flanges, install bolts and run up nuts. Tighten flange nuts to correct torque, working diagonally opposite nuts in sequence around the periphery.

KTM SERIES EB7 UNIBODY FLOATING BALL VALVES

INSTALLATION AND OPERATION MANUAL

2.5 Low temperature valves

Low temperature ball valves are supplied with valve end protection caps or covers. These protective covers should remain on the valve until installation. As dust, grit and moisture will affect the performance and sealing capabilities of these valves, every effort should be made to protect and preserve these valves from adverse conditions including moisture.

2.6 Testing installations

When pipeline or vessel installations are being tested it is desirable to have all ball valves in the 'open' position. DO NOT USE ball valves as block valves when testing pipelines or vessels as sealing mechanism may be seriously damaged by foreign matter. Should valves be used for such testing, the manufacturer takes NO RESPONSIBILITY for any damage which may affect the valves sealing mechanism and all guarantees are withdrawn. If the user decides to test such installations with the valves 'closed', caution should be exercised to ensure that the sealing mechanism is not subjected to pressure differentials in excess of the maximum operating pressure of the valve seat design.

2.7 Operating instructions

Opening and closing is readily accomplished by a quarter turn rotation of the valve shaft. Valve shafts are milled with two flats, the parallel sides of which are in line with the bore of the valve or circular with one key with arrows stamped on top of the shaft to indicate ball bore position. 'Stops' are provided at each extremity to full 'open' or full 'closed'. When valves are supplied with gear operators or actuators, the 'stops' within such units are factory adjusted and synchronised with the ball valve 'stop'. Should gear operators or actuators be field fitted, caution should be exercised to ensure that 'stop' adjustment is checked and synchronised with the valve 'stop'.

Valves may be fitted with actuators and other accessories with speed controls factory set to achieve an operating speed to meet the requirements of client's specification. On installation, should you desire a slower operation, speed controls covering both the open and closed operating speeds can be adjusted to your requirements. Refer to specific electrical pneumatic circuit diagrams for details of speed controls.

All valves have been tested in the factory. Therefore we do not consider it necessary for any additional tests to be carried out on site.

2.8 Recommended spares for commissioning

Commissioning spares should not be required if all of Emerson's recommendations are followed for installation. Recommended spare part holdings would typically be 10% but will vary depending of installation base. Spare part kits are available through Emerson Sales Offices.

3 MAINTENANCE

The only routine maintenance required is periodical checks and adjustment to the shaft assembly. Adjustment to the gland nut is recommended after the first 3000 and 5000 cycles thereafter to compensate for the bedding of thrust and gland seal and ensure leak free operation.

When tightening the gland nut, do not exceed recommended torques. See table overleaf. After reaching recommended gland nut torque, back off to nearest flat on nut. Bend the lock washer over the nut in this position. When fitting actuators to valves follow the mounting instructions supplied with the mounting kit.

KTM SERIES EB7 UNIBODY FLOATING BALL VALVES

INSTALLATION AND OPERATION MANUAL

4 DISASSEMBLY INSTRUCTIONS FOR DN 15 TO 40 (NPS ½ TO 1½)

1. Remove the valve from the pipeline by undoing the flange bolts and discard the old flange gaskets. Ensure that there is no hazardous matter in the valve. If this is a possibility, the valve needs to be decontaminated prior to disassembly.
2. Turn the ball to the closed position and holding the valve body (001) firmly, withdraw the body insert (002) using a suitable tool to engage with the hex drive recess in the insert. The insert is unscrewed by rotating in an anticlockwise direction.
3. Using a pointed scribe, pick out and remove both PTFE insert seal (003) and the graphite fire safe seal (026) from within the valve body. The insert end seat (101) can now be removed.
4. The ball (100) can now be removed. This may necessitate turning the valve so that it can be gently tapped with a soft object so as not to dent the face of the ball. Care should be taken that the ball does not fall from the valve, thus causing damage.
5. The other body seat (101) can then be removed from the body. Care should be taken when doing this so not to damage the firesafe edges on firesafe valves.
6. The handle can now be removed, by undoing the nut (301) and removing the wrench (300).
7. Straighten out the lock washer (258) and remove the gland nut (207).
8. Remove the shaft spring (206) and gland (213) from the shaft and push the complete shaft through into the body of the valve from where it may be withdrawn.
9. For DN 15 to 25 (NPS ½ to 1) valves the shaft seals (201 and 202) gland packing (217) and thrust washer (204), for DN 40 (NPS 1½) valve the weather seal (251) and auxiliary shaft seal (235) can then be removed from the valve body both internally and externally from the shaft bore taking care not to damage the machined faces.
10. The components should then be cleaned and checked for wear and damage. If replacement parts are required other than the seat and shaft seal kit, refer to Emerson Sales Office for part numbers and availability.

Note: DN 25 (NPS 1) valve illustrated

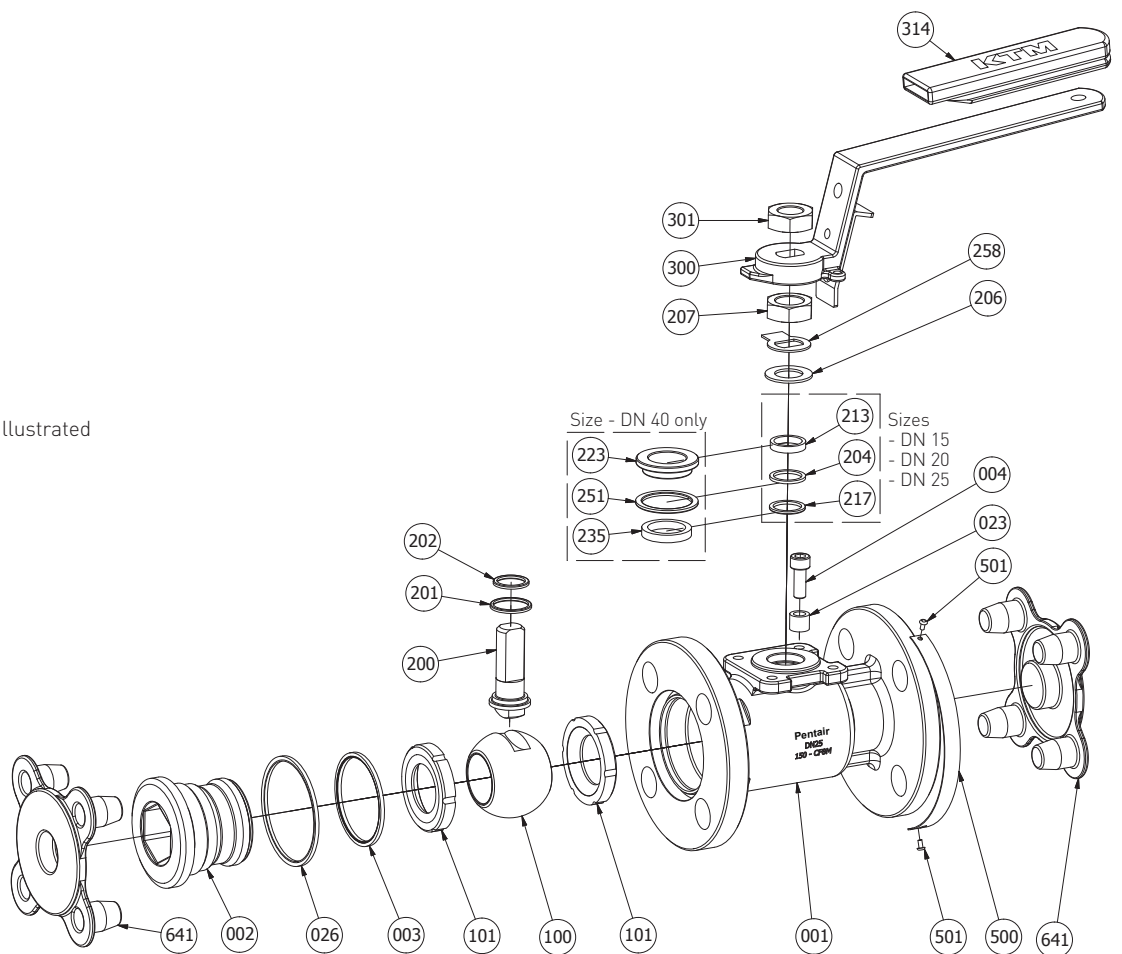

KTM SERIES EB7 UNIBODY FLOATING BALL VALVES

INSTALLATION AND OPERATION MANUAL

5 ASSEMBLY INSTRUCTION FOR DN 15 TO 40 (NPS 1/2 TO 1 1/2)

1. Check that all components are clean and that there is no damage, which will affect the performance of the rebuilt valve. Specific care should be taken in inspecting the firesafe lip to ensure that it is free from nicks or other imperfections. Lubricate external surface of ball and seal sealing faces with a lubricant compatible with service conditions.
2. Insert the seat (101) into the cavity of the valve.
3. Place the primary shaft seal (201) and firesafe shaft seal (202) onto the base of the shaft (200). Insert the shaft (200) into the valve body (001) from inside the bore of the valve.
4. Whilst holding the shaft in position, fit the gland packing (217) and upper thrust washer (204). Note for DN 40 (NPS 1 1/2) valves fit auxiliary shaft seal (235) and weather seal (251).
5. Fit the gland (213) and spring washer (206).
6. Fit the lock washer (258). Lubricate thread with anti-seize compound and screw down the gland nut (207) hand tight.
7. Ensure that the shaft (200) is in the closed position and slip the ball (100) into position in the valve body (001). Ensure that the antistatic spring (531) is in position as the ball is inserted.
8. Place the other seat (101) in position and fit the body seal (003) into the body recess. A flat bladed screw driver can be used to assist in positioning the insert seal within the recess.
9. Position the auxiliary body seal (026) into flange face recess. Great care should be taken with the auxiliary body seal as it is manufactured from flexible graphite and can be easily damaged.
10. Lubricate the thread on the body insert with a copper based grease.
11. Screw in the body insert clockwise, and tighten down to recommended torque.
12. Tighten down the shaft nut to recommended torque and back off until the flat lines up with the tab on the lock washer. Bend up the lock washer to lock the nut in this position.
13. Refit the handle (300) and handle nut (301).
14. Check the valve for operation and if possible, perform a pressure test on the bench to ensure that the valve has been correctly reassembled.

TORQUE VALUES (METRIC)

Valve size (DN)	Gland torque (Nm)*	Body insert torque (Nm)
15	12	160
20	30	300
25	30	350
40	40	400

TORQUE VALUES (IMPERIAL)

Valve size (NPS)	Gland torque (in/lb)*	Body insert torque (in/lb)
1/2	106	1416
3/4	266	2655
1	266	3098
1 1/2	354	3540

NOTE

* Tighten to correct torque and back off to nearest flat on nut.

Note: DN 25 (NPS 1) valve illustrated

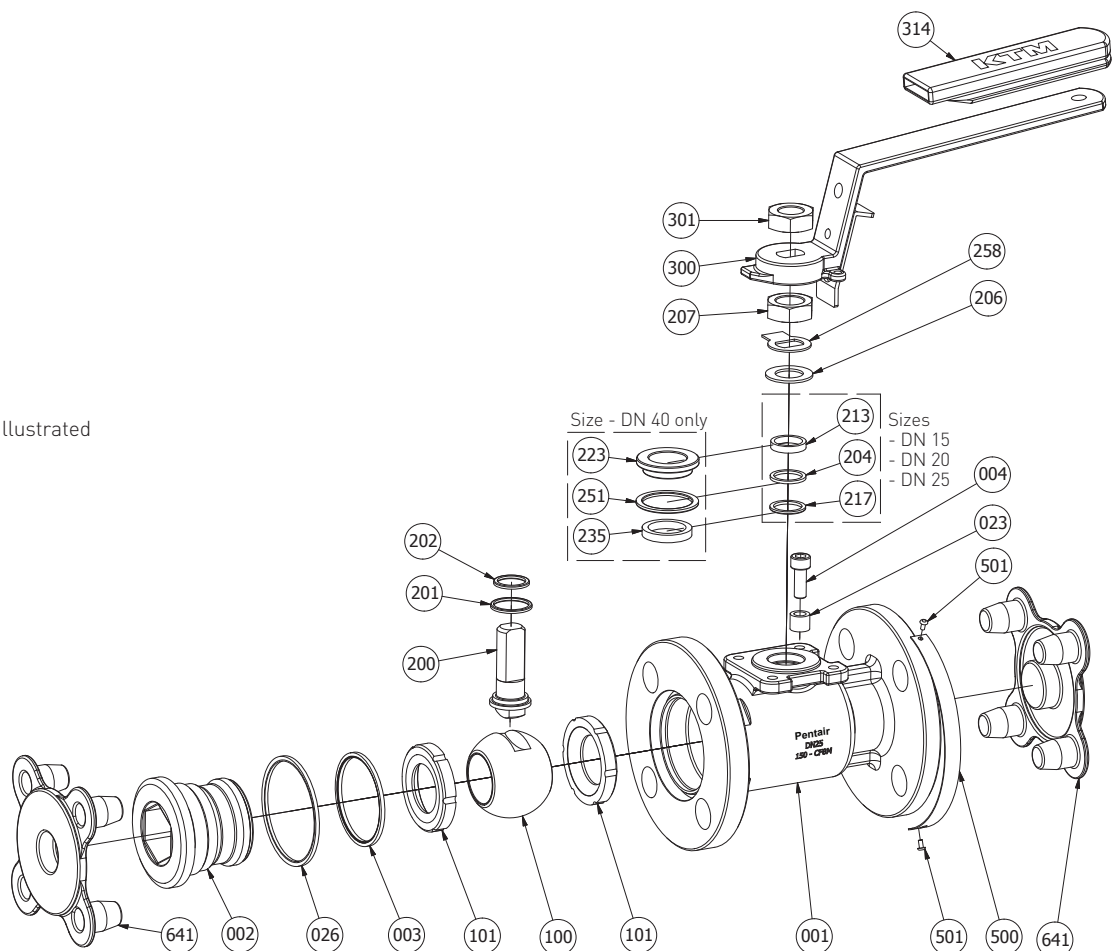

KTM SERIES EB7 UNIBODY FLOATING BALL VALVES

INSTALLATION AND OPERATION MANUAL

6 DISASSEMBLY INSTRUCTIONS FOR DN 50 TO 200 (NPS 2 TO 8)

1. Remove the valve from the pipeline by undoing the flange bolts and discard the old flange gaskets. Ensure that there is no hazardous matter in the valve. If this is a possibility, the valve needs to be decontaminated prior to disassembly.
2. Turn the ball to the closed position and holding the valve body (001) firmly, withdraw the body insert (002) using a suitable tool to engage with the drive slots in the insert. The insert is unscrewed by rotating in an anticlockwise direction. Completely remove the insert together with the body insert seal (003) and seat (101).
3. The ball (100) can now be removed. This may necessitate turning the valve handle so that the ball can be gently tapped with a soft object so as not to dent the face of the ball. Care should be taken that the ball does not fall from the valve, thus causing damage.
4. The other seat (101) can then be removed from the body. Care should be taken when doing this not to damage the fire safe edges on fire safe valves.
5. The handle (300) can now be removed;
 - a) On valve sizes up to and including DN 50 (NPS 2) this entails undoing the nut (301) and removing the wrench (300).
 - b) On sizes DN 80 (NPS 3) and above, the wrench retainer bolt (301) needs to be removed whereupon the wrench head (303) can be removed.
6. Straighten out the lock washer (258) (DN 50 (NPS 2) valve only) and remove the gland nuts (207).
7. Remove the shaft spring (206) and gland (213) or shaft seal follower (223) from the shaft and push the complete shaft through into the body of the valve from where it may be withdrawn.
8. The shaft seals (201) and (202), auxiliary shaft seal (235) and shaft thrust washer (204) can then be removed from the valve body both internally and externally from the shaft bore taking care not to damage the machined faces.
9. The components should be cleaned and checked for wear and damage. If replacement parts are required other than the seat and shaft seal kit, refer to Emerson Sales Offices for part numbers and availability.

Note: DN 50 (NPS 2) valve illustrated

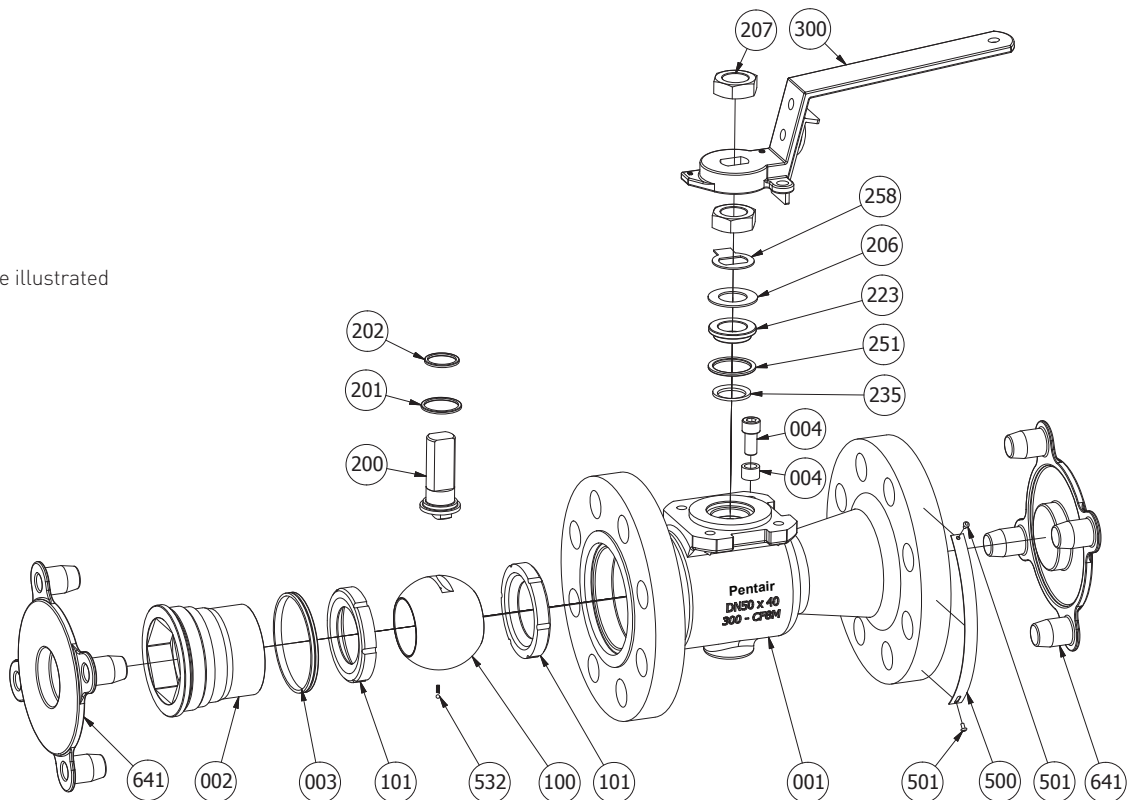

KTM SERIES EB7 UNIBODY FLOATING BALL VALVES

INSTALLATION AND OPERATION MANUAL

7 ASSEMBLY INSTRUCTION DN 50 TO 200 (NPS 2 TO 8)

1. Check that all components are clean and that there is no damage that will affect the performance of the rebuilt valve. Specific care should be taken in inspecting the fire safe lip to ensure that it is free from nicks or other imperfections. Lubricate external surface of ball and seat sealing faces with a lubricant compatible with service conditions.
2. Cantilever seat. Place seat (001) in each seat pocket body (001) and body insert (002).
3. Place the primary shaft seal (201) and fire safe shaft seal (202) onto the base of the shaft (200). Insert the shaft (200) into the valve body (001) from inside the bore of the valve.
4. Whilst holding the shaft in position, fit auxiliary shaft seal (235), followed by weather seal (251), followed by shaft seal follower (223), followed by stop plate (205).
5. Fit the shaft spring (206).
6. Fit the lock washer (258) (DN 50 (NPS 2) valve only). Lubricate thread with anti-seize compound and screw down the shaft nut (207) hand tight.
7. Ensure that the shaft (200) is in the closed position and slip the ball (100) into position in the valve body (001).

Note: for DN 50 (NPS 2) valve ensure that the Antistatic Device (532) is in position as the ball is inserted.

8. Place the other seat into position and fit the body insert seal (003) into the body cavity.
9. Lubricate the thread on the body insert with copper-based grease.
10. Screw in the body insert (002) and tighten down to recommended torque – refer table or until the insert is level with the flange face, but no more than 0.25 mm (0.1 inch) below.
11. For DN 50 (NPS 2) valves, tighten down the shaft nut (207) to recommended torque and back off until the flat lines up with the tab on the lock washer (258). Bend up the lock washer to lock the nut in this position.
12. For DN 80 (NPS 3) and larger valves, tension shaft until the shaft spring is fully compressed, then back off a quarter of a turn and lock into position with upper shaft nut.
13. Refit wrench assembly.
14. Check the valve for operation, it should be smooth and firm during the cyclic operation. If possible, perform a pressure test on the bench to ensure that the valve has been correctly reassembled.

TORQUE VALUES (METRIC)

Valve size (DN)	Gland torque (Nm)*	Body insert torque (Nm)
50	40	400
80	95	600
100	95	700
150	150	900
200	150	1300

TORQUE VALUES (IMPERIAL)

Valve size (NPS)	Gland torque (in/lb)*	Body insert torque (in/lb)
2	354	3540
3	841	5310
4	841	6196
6	1328	7966
8	1328	11506

NOTE

* Tighten to correct torque and back off to nearest flat on nut.

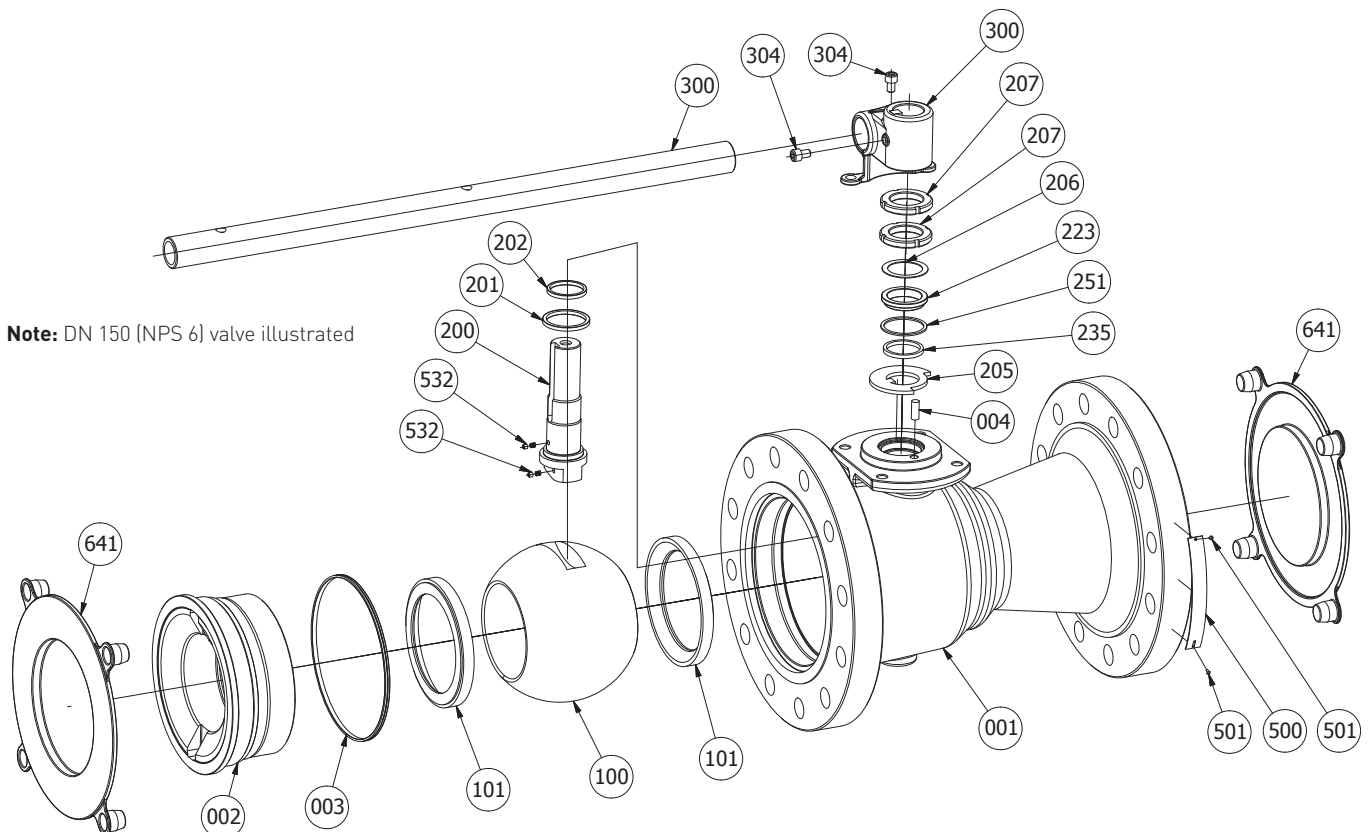

Neither Emerson, Emerson Automation Solutions, nor any of their affiliated entities assumes responsibility for the selection, use or maintenance of any product. Responsibility for proper selection, use, and maintenance of any product remains solely with the purchaser and end user.

KTM is a mark owned by one of the companies in the Emerson Automation Solutions business unit of Emerson Electric Co. Emerson Automation Solutions, Emerson and the Emerson logo are trademarks and service marks of Emerson Electric Co. All other marks are the property of their respective owners.

The contents of this publication are presented for informational purposes only, and while every effort has been made to ensure their accuracy, they are not to be construed as warranties or guarantees, express or implied, regarding the products or services described herein or their use or applicability. All sales are governed by our terms and conditions, which are available upon request. We reserve the right to modify or improve the designs or specifications of such products at any time without notice.

[Emerson.com/FinalControl](https://www.emerson.com/FinalControl)