



KEYSTONE FIGURE 85/86 CHECK VALVES INSTALLATION AND MAINTENANCE INSTRUCTIONS

Please read these instructions carefully



Hazard potentials:

- disregarding of instructions
- improper use of product
- insufficiently qualified personnel

Valve application to be within the pressure temperature limits indicated in the P/T diagram.

Essential points and functions of the valve should be inspected on a regular basis.

1 STORAGE AND HANDLING

1.1 PROTECTION

Keystone valves are delivered with protection in accordance with the Keystone Engineering Instructions, to protect the valve seats and disc from damage. Wrapping and/or covers should be left in place until immediately before fitting to the pipe.

1.2 STORAGE

When valves are to be stored for some time before being fitted, storage should be in the original delivery crates or cases. Storage should be off the ground in a clean, dry indoor area.

1.3 HANDLING

1.3.1 Packed valves

Lifting and handling of the packed valves in crates should be carried out by appropriate lifting equipment. If a fork lift truck is used, appropriate fork hitches are required. The lifting and handling of packed valves in cases will be carried out in the lifting points. The transportation of all packed material should be carried out safely and according the local safety regulations.

1.3.2 Unpacked valves

The lifting and the handling of these valves has to be carried out by using appropriate means and by respecting the carrying limits. The handling must, preferably, be carried out on pallets, protecting the machined surfaces and seat to avoid damage.

When lifting the large dimension valves, the sling and the hooking of the load must be carried out by using the appropriate tools (brackets, hook, fasteners) and load balancing tools in order to prevent the valves from falling or moving during the lifting and handling. The valve may be lifted only by slings attached to the flange holes or valve body; never to valve opening.

KEYSTONE FIGURE 85/86 CHECK VALVES

INSTALLATION AND MAINTENANCE INSTRUCTIONS

2 INSTALLATION

WARNING

For safety reasons, it is important to take the following precautions before you start work on the valve:

1. Personnel making any adjustments to the valves should utilize suitable equipment. All required personal protection means should be worn.
2. The line must be depressurized before installing the valve.
3. Personnel trained in all aspects of manual and mechanical handling techniques must carry out handling of the valves.
4. Misuse of the valve is not allowed. For example: the valve, handles, actuators or other parts may not be used as "climbing tools".
5. Ensure that valve pressure/temperature limitations marked on the identification tag are within the service conditions. The trim number on the valve's tagplate identifies the valve materials. See Product Manual for valve specific P/T diagram and trim number definition.
6. Ensure that valve materials are compatible with the pipeline fluid.

2.1 VALVE INSPECTION

1. Carefully remove the valve from the shipping package (box or pallet) avoiding any damage to the valve or instrumentation.
2. Confirm that the materials of construction listed on the valve nameplate are appropriate for the service intended and are as specified.
3. It is not allowed to use third party spare parts. In case of third party spare parts, safe operation is not guaranteed.

2.2 FLANGE AND PIPE COMPATIBILITY

Check matching of flange drilling pattern of pipe and valve body outside diameter before assembly.

Flange face which contacts valve body has to be flat and without any scratches or other damage.

The figure 85 is a check valve of a swing-type concept. The geometry is chosen in such a way that the pipeline is being used as disc travel stop. Valves should be installed between flanges in a straight pipeline according ISO 4200 of the same nominal size as the valve. The pipe schedule determines the disc openings angle. Do never install a figure 85 swing-type check valve just upfront a compensator, an expander pipe-coupling or an elbow fitting. The disc shaft connection might be damaged due to the lack of a well defined travel-stop function to the pipe. Gaskets are not required.

The figure 86 is a check valve of a swing-type concept. The valve body of figure 86 is equipped with an internal travel stop which stops the disc in full open position. The disc is not allowed to touch the pipeline inside. The minimum flange face inside diameter (D min.) for figure 86 is equal to the valve Q-dimension + adequate disc clearance. Gaskets are required.

FIGURE 85

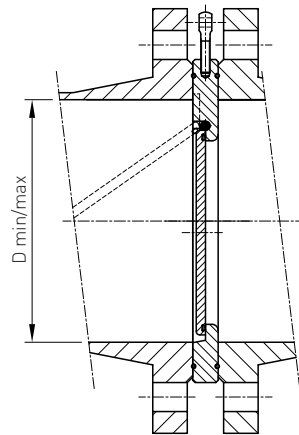
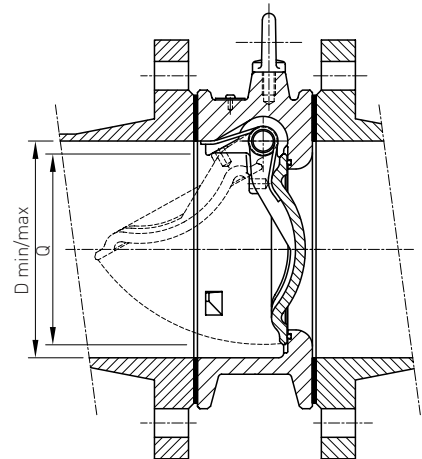
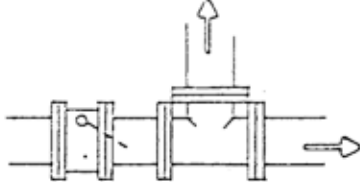
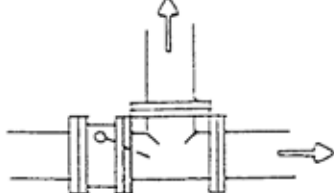
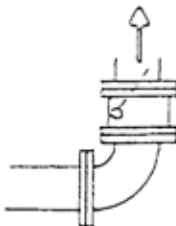
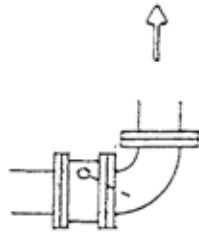

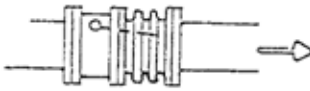
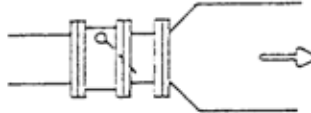
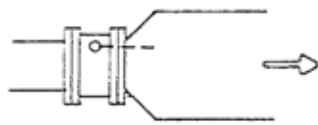
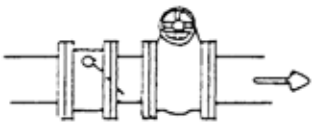
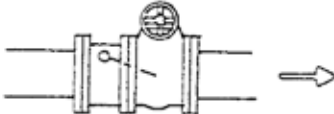

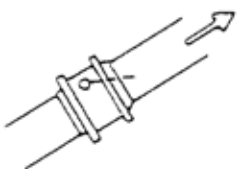
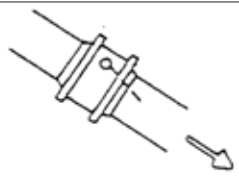

FIGURE 86



KEYSTONE FIGURE 85/86 CHECK VALVES
 INSTALLATION AND MAINTENANCE INSTRUCTIONS

DO	DO NOT
1. Smooth flow 	1. Valve too close to branch Turbulence of flow makes disc flutter 
2. Smooth flow 	2. Valve too close to elbow Turbulence of flow makes disc flutter No travel stop (figure 85 only) 
3. Proper travelstop function by pipeline 	3. No travelstop (figure 85 only) 
4. Proper travelstop function by pipeline 	4. No travelstop function by the pipeline (figure 85 only) 
5. Sufficient disc clearance 	5. Disc may interfere with valve obturator 
6. Upward flow direction with gravity closing disc 	6. Only high backward flows will compensate disc mass/gravity 
7. Upward flow direction with gravity closing disc 	7. Only high backward flows will compensate disc mass/gravity 

KEYSTONE FIGURE 85/86 CHECK VALVES

INSTALLATION AND MAINTENANCE INSTRUCTIONS

2.3 VALVE INSTALLATION

The check valve figure 85 is a wafer type check valve which is mounted in between two pipeflanges. In both facings of the valve-body, O-rings are incorporated for a proper flange sealing. Do not use additional gaskets.

For figure 86 check valves flange sealing is not incorporated in the valve. Standard flange gaskets should be used.

All check valve must be installed with the indication arrow pointing in the flow direction of the pipeline flow.

Considerable turbulences are caused at the pressure outlet end of any pump and highly affect the function and the life of any non-return device. Check valves should thus not be installed directly next to the pump out-let, but at a distance of at least five times DN after the pipe flange joint. Only this arrangement can ensure smooth flow through the check valve and its trouble free function. Pulsating flow must in any case be avoided, as it entails a heavy effort on the sealing element in the valve disk and a rapidly increasing wear of the valve stem pivots.

NOTES

- Do not use the valve as a support of the pipe line construction.
- Handling and lifting of the valves during installation MUST be performed following the same instructions described in previous paragraph "1.3 Handling".
- Adjacent piping must be positioned so that minimal piping stresses are transmitted to the valve flanges during or after installation.

IMPORTANT

Mating flange faces should be in good condition and free of dirt and/or inclusions. Both pipe insides to be well cleaned.

2.3.1 Horizontal pipe

1. Check whether the flange distance meets the valve face-to-face dimensions. Spread with adequate tooling the flanges for easy insertion of the valve.
2. Insert some flangebolts in the pipeflanges, to help you bear the valve after insertion.
3. Insert the valve between the flanges and position the hinge point of the disc in the most upright direction and flow indication arrow on the body pointing in flowdirection. For figure 86 insert also the two flange gaskets.
4. Insert all flange bolts, tighten the flange-bolts hand tight and center the valve body versus the flanges.
5. Maintain the valve flange alignment while gradually removing the flange-spreaders and tighten the flange-bolts. Cross-tighten all bolting to the proper torque. Do not overtighten.

2.3.2 Vertical pipe

1. Check whether the flange distance meets the valve face-to-face dimensions. Spread with adequate tooling the flanges for easy insertion of the valve.
2. Insert some flangebolts in the pipe flanges.
3. Insert the valve between the flanges. For figure 86 insert also the two flange gaskets. Flow area indicator on the valve body pointing upwards. In vertical piping, the check valve can only be mounted in a pipe with an upwards flow direction so that the gravity closes the valve in case of no-flow or backwards flow.
4. Insert all flange bolts, tighten the flange-bolts hand tight and center the valve body versus the flanges.
5. Maintain the valve flange alignment while gradually removing the flange-spreaders and tighten the flange-bolts. Cross-tighten all bolting to the proper torque. Do not overtighten.

2.4 SOURCES OF POSSIBLE DANGER

This section contains some examples of possible foreseen danger sources.

2.4.1 Mechanical

- A) When manual operators are used, available space should be checked in order to avoid hands being clamped.
- B) Mechanical sparks caused on impact of valve and e.g. tooling, are a potential source of ignition of surrounding atmosphere.

2.4.2 Thermal

- A) If the valve is used in applications with a fluid temperature above 40°C the outside of the body might be hot. Sufficient measurements should be taken to avoid burning. A manual operated valve should be opened and closed with sufficient protection for the personnel operating the valve. For example: protecting gloves.
- B) Hot surfaces can be a potential source of ignition of the environment.

2.4.3 Operational

A too high back flow will result in water hammer in the upstream part of the pipeline if the valve closes. A high return flow rises because of a too high deceleration of the flow. Water hammer results in excessive pressures in the valve and pipeline. Water hammer can cause severe damage. Water hammer should be avoided in all circumstances.

KEYSTONE FIGURE 85/86 CHECK VALVES

INSTALLATION AND MAINTENANCE INSTRUCTIONS

3 MAINTENANCE

The Keystone valves Figure 85 and Figure 86 are designed to require a minimum of maintenance.

WARNING

Depressurize and, if necessary in case of dangerous fluids, drain the line and flush with appropriate cleaning fluid before starting any maintenance. Failure to do so may cause serious personal injury and/or equipment damage. Before disassembling the valve, ensure the valve has been decontaminated correctly from any harmful gasses or liquids and that it is within a safe temperature range for handling. Personnel making any adjustments to the valves should utilize suitable equipment. All required personal protection means should be worn. Only personnel trained in all aspects of manual and mechanical handling techniques must carry out handling of all valves.

3.1 ROUTINE MAINTENANCE

Routine maintenance or lubrication is not required.

3.2 REMOVING THE VALVE

1. Loosen all flange bolts and remove the bolts which prevent removing the valve.
2. Spread the flanges with adequate tooling, and remove the valve.

3.3 VALVE DISASSEMBLY (FIGURE 85)

1. Remove lifting eye-bolt.
2. Remove countersunk screws.
3. Separate body and disc.
4. Remove the O-rings (body and disc).

Valve disassembly (figure 86)

1. Remove lifting eye-bolt.
2. Remove plug and seal.
3. Pull shaft out off body and disc by using threaded hole in shaft.
4. Separate body, spring and disc.
5. If required remove the two bushings
6. Remove the O-ring (body).

3.4 VALVE ASSEMBLY (FIGURE 85)

1. Clean all parts. Do not put oil or grease in O-ring grooves.
2. Carefully place the O-rings in the body and disc.
3. Position the disc in the body.
4. Place the washers and countersunk screws.
5. Tighten the screws.
6. Place the lifting eye-bolt.

Valve assembly (figure 86)

1. Clean all parts. Do not put oil or grease into the O-ring groove.
2. Carefully place the O-ring in the body.
3. Place the two bushings.
4. Position the disc in the body.
5. Place the spring, keep the spring in place while sliding the shaft into the body.
6. Place the seal and tighten the plug.
7. Place the lifting eye-bolt.

3.5 RE-INSTALLING THE VALVE

See paragraph 2.3.

KEYSTONE FIGURE 85/86 CHECK VALVES

INSTALLATION AND MAINTENANCE INSTRUCTIONS

FIGURE 85

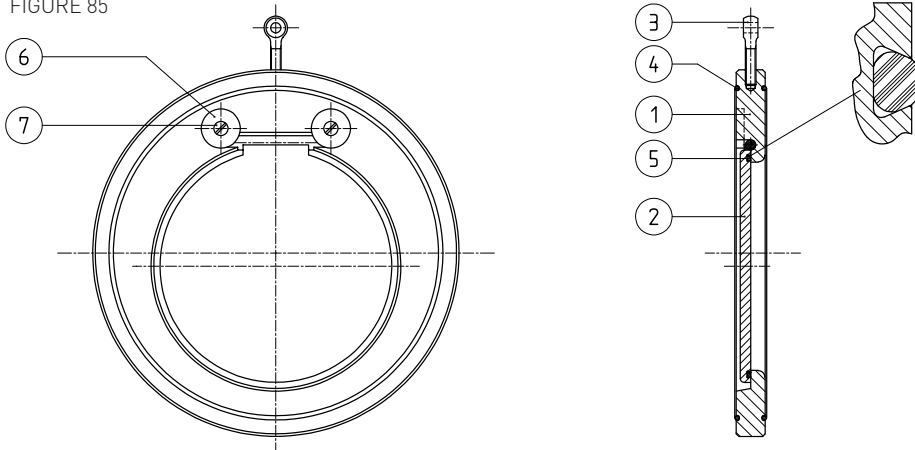

Parts identification

1	Body	5	Disc O-ring
2	Disc	6	Washer
3	Lifting eyebolt	7	Countersunk screws
4	Body O-ring		

FIGURE 86

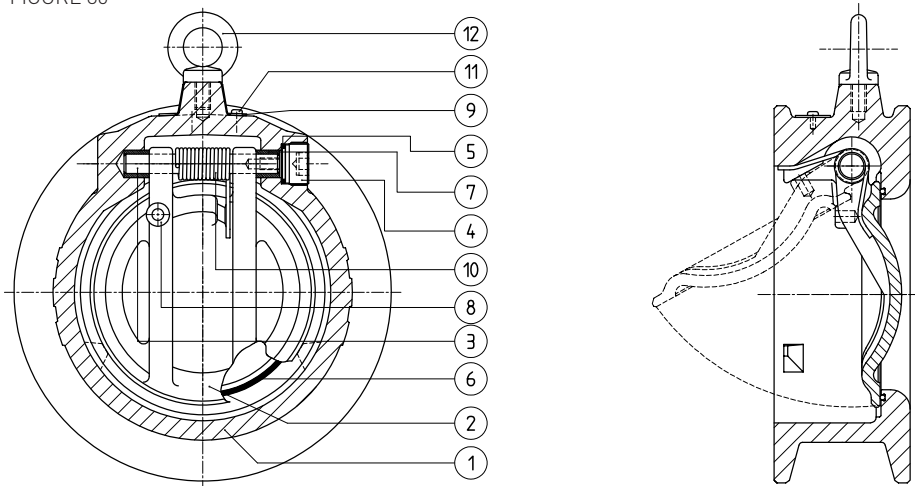

Parts identification

1	Body	7	Bushing
2	Disc	8	Travelstop
3	Shaft	9	Tagplate
4	Plug	10	Spring
5	Seal	11	Rivet
6	O-ring	12	Eyebolt

Neither Emerson, Emerson Automation Solutions, nor any of their affiliated entities assumes responsibility for the selection, use or maintenance of any product. Responsibility for proper selection, use, and maintenance of any product remains solely with the purchaser and end user.

Keystone is a mark owned by one of the companies in the Emerson Automation Solutions business unit of Emerson Electric Co. Emerson Automation Solutions, Emerson and the Emerson logo are trademarks and service marks of Emerson Electric Co. All other marks are the property of their respective owners.

The contents of this publication are presented for informational purposes only, and while every effort has been made to ensure their accuracy, they are not to be construed as warranties or guarantees, express or implied, regarding the products or services described herein or their use or applicability. All sales are governed by our terms and conditions, which are available upon request. We reserve the right to modify or improve the designs or specifications of such products at any time without notice.